

Econo Heater

Manufactured by

EconoHeat

Waste Oil Fired Heater

Installation, operation and service instructions

EH-350 120v Manual



Table of Contents

| | |
|--|---------|
| Precautions | Page 3 |
| Important Notice | Page 4 |
| Specifications | Page 5 |
| Installation Procedures | Page 6 |
| Stack Installation | Page 7 |
| Oil Supply Tubing | Page 7 |
| Wiring | Page 8 |
| Oil Burner | Page 9 |
| Oil Burner Technology | Page 10 |
| Initial Start Procedure | Page 12 |
| Maintenance Schedule | Page 13 |
| Figures 6 – 12 | Page 14 |
| Troubleshooting | Page 17 |
| EH-350 Ten Year Limited Warranty | Page 18 |
| Warranty Card | Page 20 |

PRECAUTIONS

Waste oil may contain many foreign materials. Waste oil may also contain gasoline. Therefore, specific precautions on the handling and storage of waste oils are to be observed when using, cleaning, and maintaining this heater. **Use a screen in a funnel when pouring oil into storage tank to catch foreign material, i.e., gasket material and sealant fibers, etc. WARNING: This appliance is not designated for use in hazardous atmospheres containing flammable vapors or combustible dust, or atmospheres containing chlorinated or halogenated hydrocarbons. Do not expose this unit to rain or moisture.** EconoHeat burns the widest range of used and new oils including, but not limited to: used motor oils up to 90 weight, transmission and hydraulic fluid, used synthetic oils, crude oil, vegetable, fish, and mineral oil, all diesel fuel and many more. Do not use old, contaminated oils that have been stored in underground tanks or outside barrels for long periods of time. Excessive water and sludge may be present, causing quick filter plugging.

NOTES: The instructions contained in this manual apply to the installation, operation, and service of EconoHeat Waste oil fired heaters. The following instructions should be carefully followed for obtaining the best possible installation, operation, and service conditions. Specifications are subject to change without notice. This heater was designed to be a primary or auxiliary heat source, but not the only source of heat. It also provides economical disposal of waste oil. Proper operation depends on the consistency of the oil. Any water or foreign material in the oil may cause the unit to shut down. If a continuous stream of oil cannot be guaranteed at the heater, the main heating system should be set above freezing which will prevent any building damage if the waste oil heater were to become inoperative during subfreezing weather, i.e. supply tank empty, filter plugged, etc. .

UNCRATING: Immediately upon uncrating units, check rating plate for certainty of electrical and mechanical characteristics. Also, check the unit for any damage that may have been incurred in shipment, if any damage is found, file a claim with the transporting agency. The unit has been tested and inspected at the factory prior to crating and was in perfect condition at that time. If anything is missing, check packing slip for indications of possible backorder of those parts or components. Otherwise, a claim must be filed for those missing parts.

IMPORTANT

Notice to the owner and installer

To enjoy the long-term benefits of burning your used oil in an EconoHeat Waste Oil Burning appliance, it is necessary to become familiar with the correct installation operation and maintenance of your new furnace. Before installing or operating this appliance, make sure you read and understand this manual.

IMPROPER INSTALLATION, ALTERATIONS, OR LACK OF MAINTENANCE WILL VOID THE WARRANTY.

The most critical sections of this manual are in order of importance as follows:

- **Basic Operation Knowledge**
- **Oil Suction Line Installation**
- **Correct Draft Over Fire**
- **General Maintenance Requirements**

Identical to any gas or oil furnace, without adequate draft over the fire, the combustion gases cannot escape the furnaces. The flame will lengthen resulting in an overheated combustion chamber. Even if the heater is installed correctly and adequate draft achieved, a flue passage blockage will affect the draft. Burning used oil is similar to burning wood. A fine gray ash accumulates in the chamber and flue passage. This accumulation of ash will eventually affect the draft. It is important to remove this ash before the draft is affected.

These topics are discussed in detail on the pages listed above. Please familiarize yourself with these sections of your manual. Spending a few minutes to review this material will assure that you receive the return on investment that you expect from your EconoHeat heater.

Specifications

| | |
|----------------------------------|---------------------|
| BTU INPUT: | 350,000 |
| BTU OUTPUT: | 300,000 |
| GALLONS PER HOUR: | 2.4 |
| REQUIRED VOLTS: | 115 |
| AMPS FULL LOAD: | 18.7 |
| FAN MOTOR HP: | 2 @ 1/4 each |
| FAN MOTOR RPM: | 1075 |
| CFM (FREE AIR): | 6275 |
| CFM w/ DUCTWORK @ 100 ft.: | 1600 |
| EFFECTIVE AIR FLOW: | 80 ft |
| FLUE SIZE: | 8" |
| WEIGHT: | 400 lbs |
| L x W x H (including burner): | 66" x 29.5" x 28.5" |
| SHIPPING WEIGHT: | 575 lbs |
| SHIPPING DIMENSIONS (L x W x H): | 76" x 38" x 49" |

Notes:

1. All illustrations and specifications contained herein are based on the latest information available at the time of publication approval. EconoHeat reserves the right to make changes at any time without notice, in materials, specifications, and models or to discontinue models.
2. These appliances are designed for commercial or industrial use only. Installation and use of this waste-oil burning appliance shall be in accordance with the Standard for the Installation of Oil Burning Equipment-ANS/NFPA 31-1987, and National Electric Code - ANSI/NFPA 70-1990 and the requirements of the inspection authorities having jurisdiction.
3. Output depends on BTU content of oil used.
4. Atomizing Air Pressure for all fuels 10 P.S.I.
5. Furnace not to be used with air filters.
6. Intended maximum outlet air temp. 200 degrees F. (93 degrees C) or less.

7. Clearance from combustible materials on all models not to be less than:

TOP- 18"

BOTTOM- 18"

SIDES- 18"

REAR- 18"

FRONT- 48"

FLUE PIPE- 18"

Mounting Dimensions:

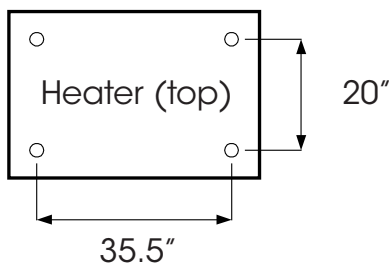

Installation Procedures

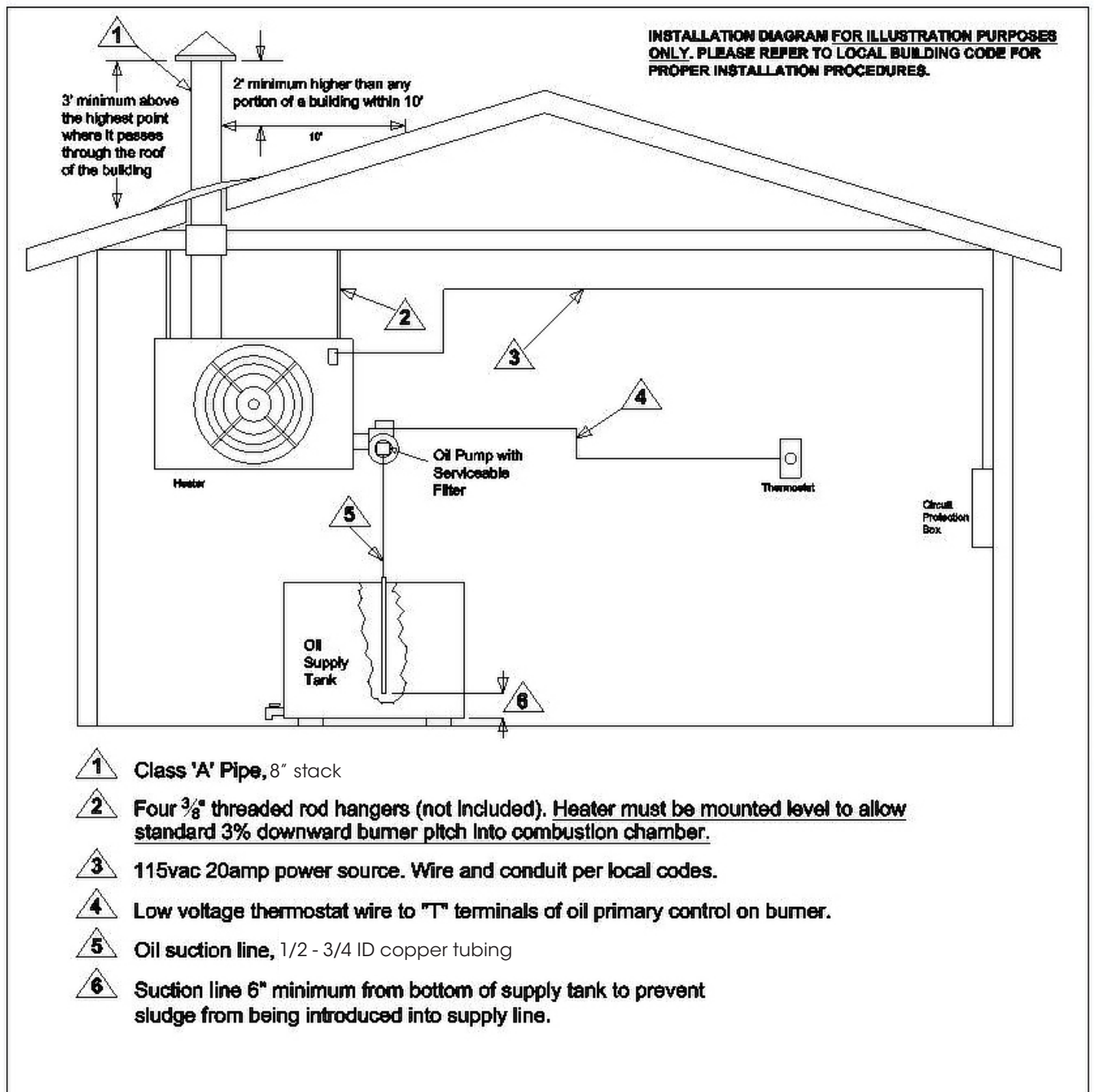

Figure 1 - Installation Diagram

Stack Installation

1. Install a barometric damper (NOT included) in the stack if the draft up the stack exceeds -.08. Draft up the stack must be minimum -.04 to -.06 inches of water column. Check with draft meter 12" from the top of the heater in (stack) or flue pipe. The over fire draft should be a minimum of -.02- check through flame inspection port. Closing the damper door can increase draft.
2. For optional draft inducers or power vent wiring, See Figure 2. One of these devices must be installed where back draft is present. In building or correct draft cannot be achieved.

Oil Supply Tubing

1. Use ONLY 1/2" or 3/4" nominal ID copper tubing with flare fittings only on the fuel suction from the tank to the heater. **Do NOT use ferrule fittings or Teflon tape on any pipe-fittings.**
2. Keep suction line approximately 6" from bottom of oil tank to prevent suction of sludge. Drain accumulated sludge and water from tank periodically.
3. Use only an inside oil storage tank to supply heater. **Do not draw from an outside tank,** especially not an underground tank, directly to heater. A separate transfer pump from an outside tank with proper filtration to the inside supply tank is acceptable and available from EconoHeat.
4. Connect 1/2" or 3/4" oil supply line from the supply tank through the filter (figure 1) to the pump inlet located same side as bleeder port (figure 4).

Wiring

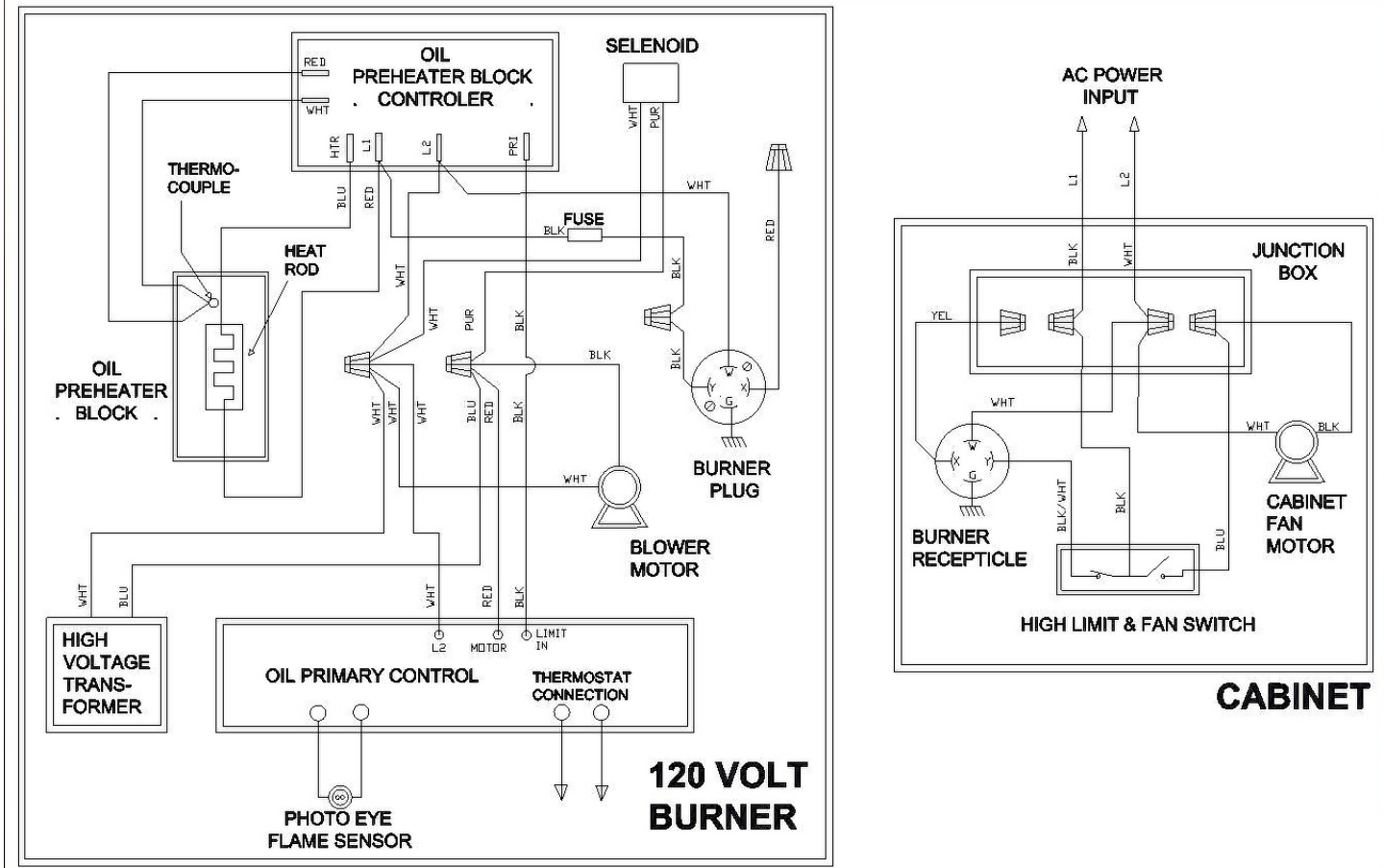

Figure 2 - Wiring Diagram

1. Wire 120V into main electrical box mounted on burner backside of heater cabinet with separate circuit **20-amp protection using 12-gauge wire**. Connect power line to black wire and all whites (NEUTRAL or COMMON) together. **IMPORTANT**, Connect ground wire to ground mounting point in main junction box (green screw).
2. Wire low voltage thermostat into "T" marked terminals on oil primary control on burner (Box on burner gun assembly with red reset button - figure 3).

Oil Burner

WARNING

Installation and use of this used oil burning appliance shall be in accordance with the standard for the Installation of Oil Burning Equipment – ANSI/NFPA 31 – 1987, and National Electric Code – ANSI/NFPA 70 – 1990 and the requirements of the inspection authorities having jurisdiction.

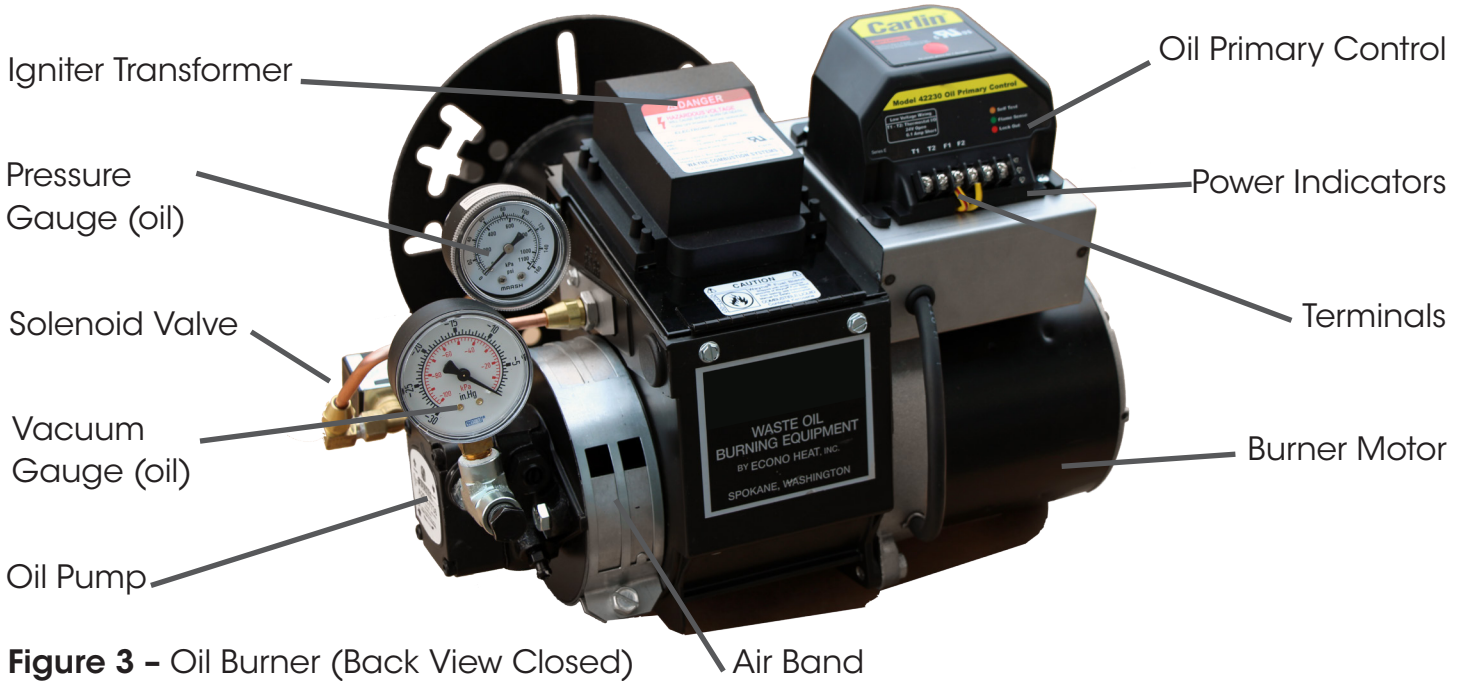

Figure 3 - Oil Burner (Back View Closed)



Figure 4 - Oil Pump

This pressure system is 150-200 psi and has the ability to control flame even when various viscosities are used- furnace or stove oil to 90 weight straight- flame remains stable

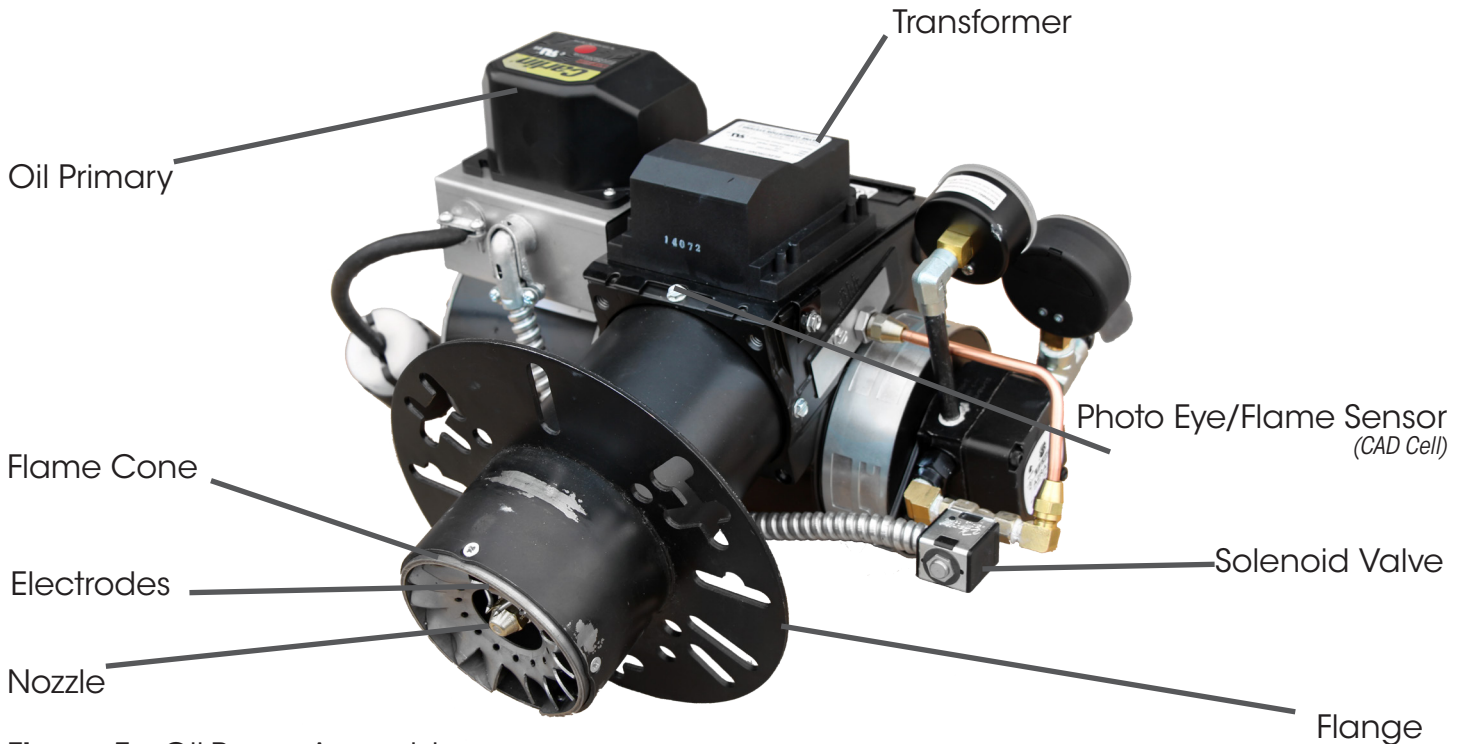
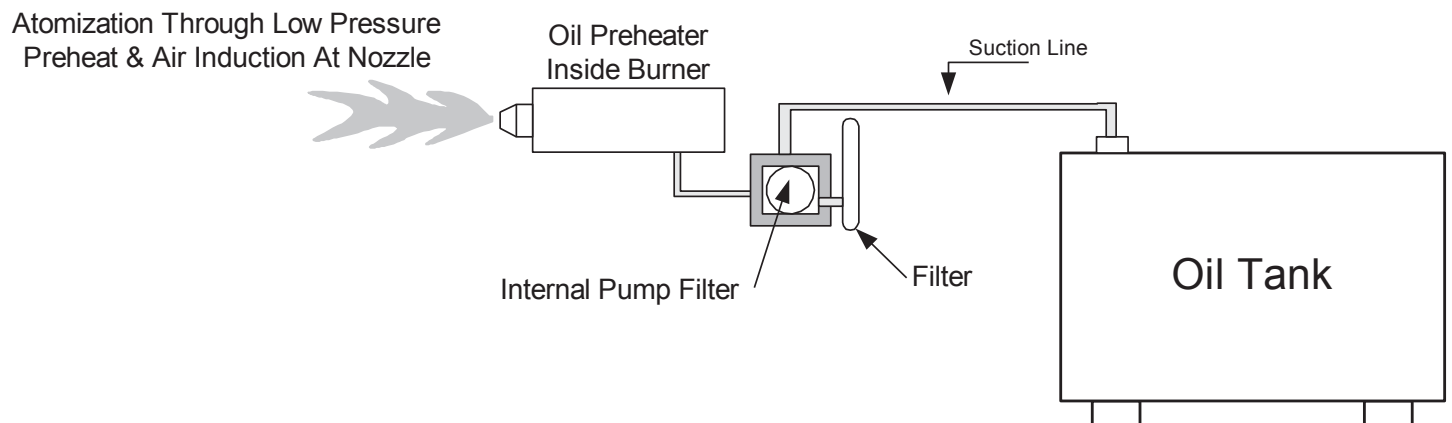

Figure 5 - Oil Pump Assembly

Oil Burner Technology



EconoHeat's patented burner technology improves the efficiency of the oil burn process by continuous stabilization of the oil viscosity. Optimum atomization (spray) is accomplished by precisely pre-heating the oil prior to introduction to the combustion chamber. The waste oil enters into the Oil Pre-Heater Block and is pre-heated to operating thermo set-point, and this along with high pressure (100 psi to 500 psi depending on model) break up the oil droplets into a finer mist or spray (atomization). Electrodes mounted just above the nozzle provides continuous electrical arc across electrode to electrode igniting the fine oil mist as it sprays out of the nozzle. Once ignited the flame is forced into a swirl caused by the burners blower and specially designed flame cone providing a very efficient and thorough burn of the waste oil.

Burner Components

- **Igniter Transformer:** (figure 3) Supplies high voltage to the electrodes generating electrical arc igniting the oil.
- **Oil Valve:** (figure 3) energizes when burner is running and de-energizes when burner is not running eliminating bleed back of oil out of the Pre-heater block.
- **Oil Primary Control:** (figure 3) Controls the oil burner ignition. Checks for flame in the combustion chamber, if no flame is detected within 45 seconds, the oil primary will shutdown the oil burner. To restart the unit, reset the red button on the oil primary.
- **Oil Pre-Heater Block:** (figure 9) Pre-heats the oil before entering combustion chamber.
- **Photo Eye:** (figure 5) Senses flame in combustion chamber and signals oil primary when no flame is present (located under hinged transformer).
- **Igniter Springs:** (figure 5) Transfers the high voltage from the igniter transformer to the electrodes (when door is closed)
- **Pre-Heater Control Circuit Board:** (figure 9) Precisely controls temperature of the Oil Pre-Heater Block and controls safety feature of not allowing burner to energize until oil has established operating thermo setpoint or shutdown burner if Pre-Heater Block temperature falls below shutdown thermo setpoint.
- **Electrodes:** (figure 9) Provides continuous high voltage electrical arc from electrode to electrode igniting the waste oil as it is being sprayed out of the nozzle.
- **Nozzle:** (figure 9) High-pressure nozzle for oil spray pattern.
- **Flame Cone:** (figure 5 & 6) Specially engineered flame cone forces the flame into a swirl pattern improving the burn thoroughness.
- **Burner Motor:** (figure 3) Motor turns the burner blower (squirrel cage fan) and on-board fuel pump.
- **Gallons per Hour (GPH):** Determined by pump pressure and nozzle profile size, varying by model/unit size.

IMPORTANT:

- **Power Indicator:** (figure 3) Indicates when power is present at the burner.
- **Run Indicator:** (figure 3) Indicates that the burner is ready for operation after the initial pre-heat time of approx. 5 minutes from initial power up.

Initial Start Procedure

1. **IMPORTANT** – Prior to starting the unit, pre-fill the filter and fuel line with oil to assist priming procedure. Make sure the oil supply line fittings are air tight. Vacuum leaks are notoriously hard to find. Pressurizing the line with oil in it can help to locate leaks.
2. Proper draft. Draft is the gases traveling through the heater and out the stack or flue. If exhaust fans are present in your building, chances are a draft inducer will be needed. Call our factory or see our website for help, www.econoheat.com
3. Switch the burner to the on position. During the initial power up process the burner is locked out from energizing until the oil has been properly pre-heated to operating thermo setpoint, approx 3 to 5 minute duration. Once the oil has been pre-heated, power is then applied to burner. Burner operated via room thermostat.
4. Jump the "T" terminals (thermostat terminals) on the Oil Primary Control (figure 3). Once the burner is running, temporarily jump the "F" terminals on the Oil Primary, not before burner tries to run or operate. This will allow the burner to run during the pump priming process – **don't forget to remove jumpers when primed.**
5. Priming the oil pump: Open bleeder valve one turn until all air is expelled (figure 4). This may need to be done twice to insure all air is removed. **IMPORTANT:** When fully purged and flame is established remove the temporary jumpers on "F" terminals of the Oil Primary to allow safety features of the unit to operate properly.
6. Pre-set at factory combustion air band (figure 3) should be open approximately 1/2" or until flame is clear yellow, not orange. Opening the air band too far may cause delayed in starting or even prevent the flame from establishing.

Inspect flame length through inspection door located above burner gun assembly. Flame should reach **no further than 1/2 to 3/4 way down combustion tube. NEVER ATTEMPT TO START HEATER WHEN COMBUSTION CHAMBER IS HOT AND A DELAYED START IS PRESENT.**

Suggested Maintenance Schedule

Every application varies. Monitor your needed schedules.

WEEKLY

- Drain water from storage tank.

MONTHLY

- Check your ash accumulation for best performance, remove if excessive (the size of unit, type of oil and run time are all contingent factors).
- Change or Replace Filter screen located in the pancake style housing (figure 12 below).
NOTE: every application is different and may vary depending on contamination of oils being used.

ONCE EACH SEASON (or more often, depending upon usage or contamination of oil)

- Clean the nozzle, flame-cone and oil heater block. Remove one (1) x 9/16 nut from the burner side of the cabinet to swing the burner away from the unit to easily access and clean the nozzle and flame-cone. (figure 6 below).
- Open the bolt on door on clean-out sides of the furnace. The bolt-on door opposite of the burner assembly requires the removal of the access panel allowing simple entry to the combustion chamber and heat exchanger(s) to vacuum out the accumulated ash & soot (hepa filter recommended) (figure 10 below).
- Check oil pump filter. Remove pump cover for access (figure 11 below). **CAUTION:** Be careful of gasket; clean if needed.

YEARLY

- Clean flue pipe stack-to loosen soot remove stack at top of heater and tap thoroughly. Then vacuum upper heat exchanger(s).
- Inspect electrode adjustment (figure 8 below). Due to erosion, adjustment may change.
- Replace nozzle as needed when flame deteriorates with no retention at flame cone, depending on usage (figures 6, 7, 8 and 9 below). Will lose efficiency due to erosion. This can be accessed by swinging the burner clean out door open (figure 6 below).
- **IMPORTANT:** TO TURN POWER OFF, Remove electrical plug from heater cabinet to burner. Remove 9/16" burner securing nuts, remove the burner side clean-out door. Remove nozzle with 5/8" socket (figures 6 and 7 below).

ELECTRODE ADJUSTMENTS

Electrodes are adjusted at time of manufacture. However, they should be checked periodically and at time of installation, to be sure they are set as noted in the following dimensional drawing. Swing burner clean out door back for inspection (figures 8 and 10 below). **CAUTION: TURN OFF MAIN ELECTRIC SUPPLY SWITCH BEFORE CHECKING OR ADJUSTING ELECTRODE SETTING.**

NOZZLE POSITION IN RELATION TO ENDCONE/BURNER TUBE

Tip of nozzle must be $\frac{1}{4}$ " ahead of inside radius of end-cone. If nozzle is behind inside radius of end-cone, coking will occur and end cone can become clogged (figure 8 below).

IMPORTANT NOTE: be sure nozzle is centered, if nozzle is higher than center, press nozzle down to bottom out pre-heater stand.

To adjust, remove burner from cabinet (figure 6 below), loosen Preheat Sink securing nut and set screw, push fore or aft as needed. **WARNING:** This adjustment is done at the factory and should not be moved unless figure 8 dimensions have been altered.

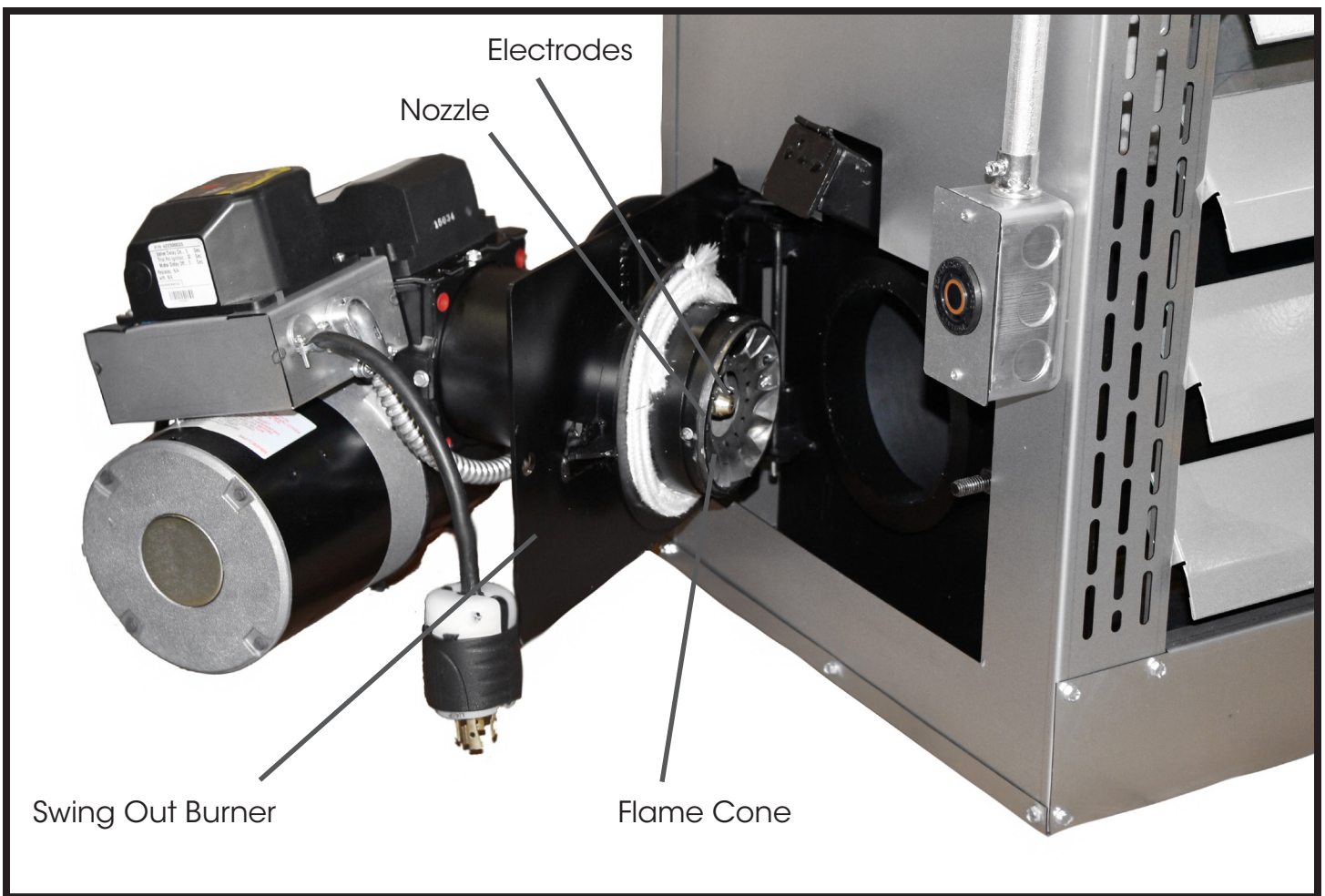
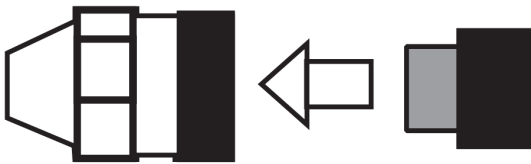

Figure 6 - Burner Door View



When cleaning, inspect all three pieces thoroughly. When disassembling and reassembling nozzle, keep facing up as shown.

Figure 7 - Nozzle Assembly Detail

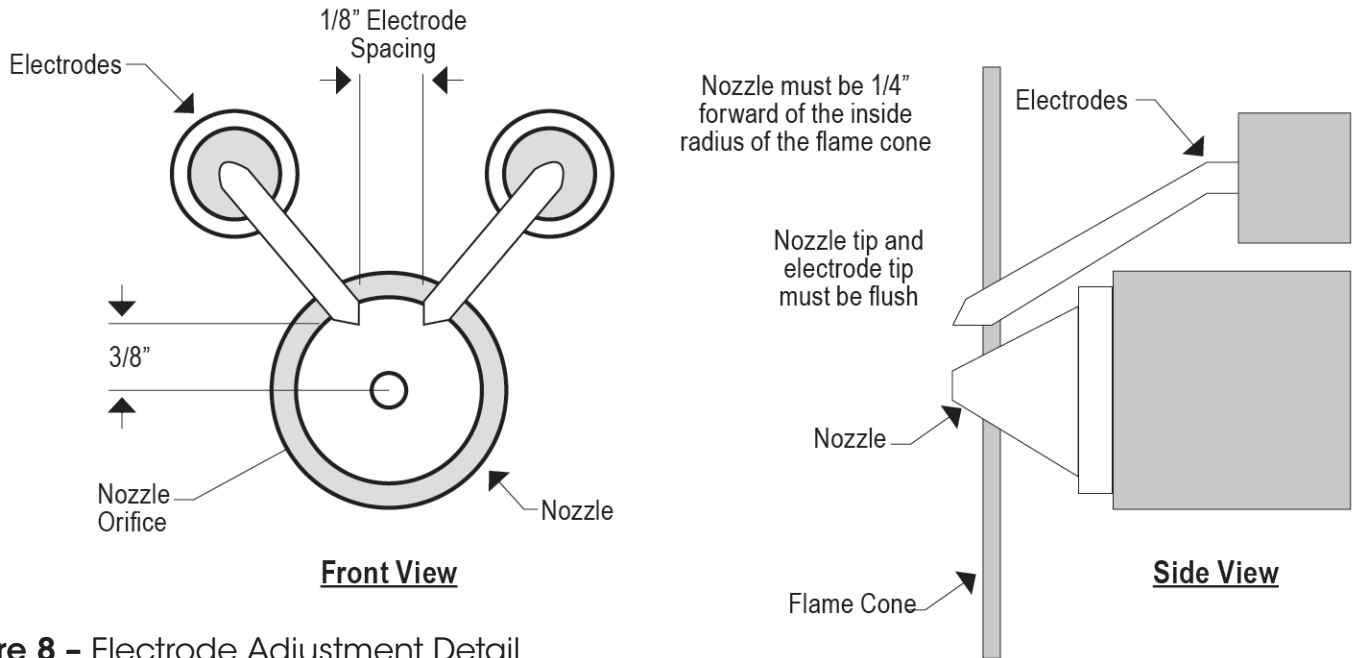

Figure 8 - Electrode Adjustment Detail

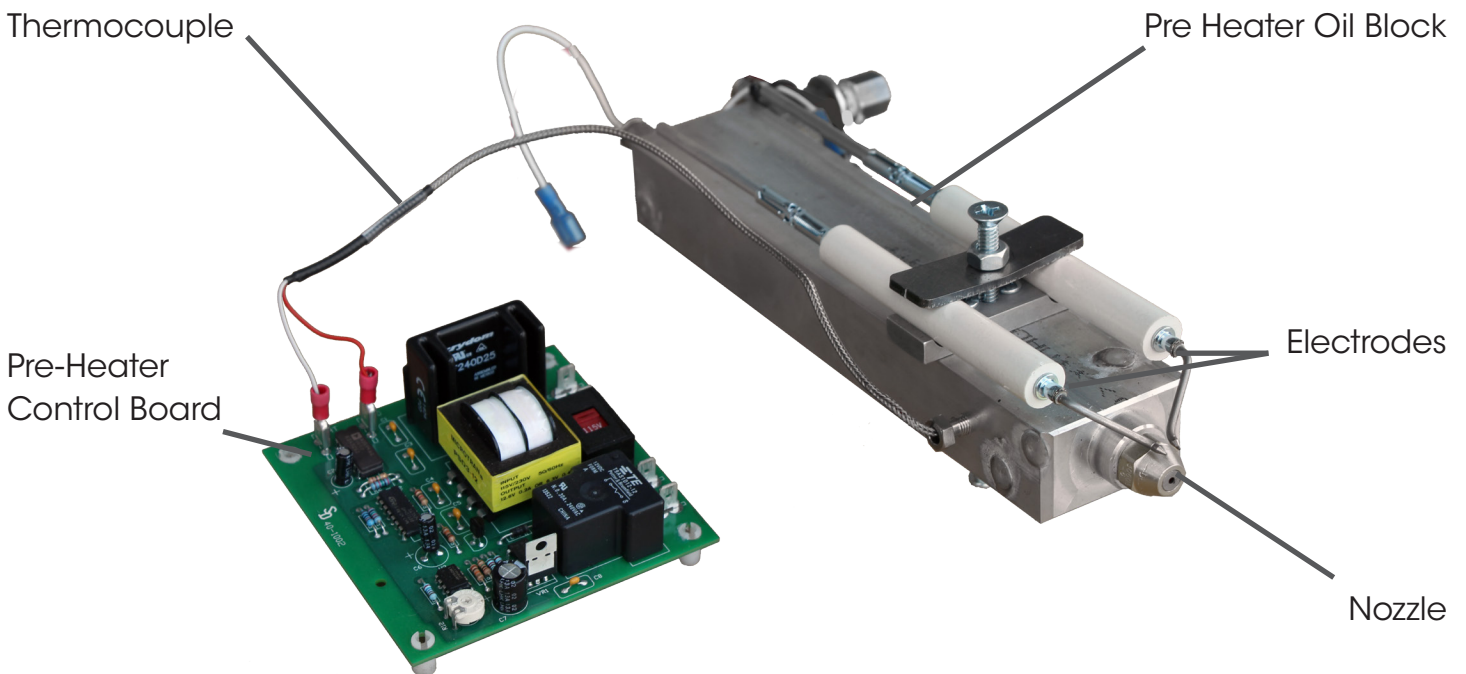

Figure 9 - Pre-Heater Block Detail (Removed From Burner for Clarity)

Remove 4 bolts for access to strainer filter.
CAUTION: must be careful not to destroy the inner gasket during removal of the housing.



Figure 10 - Pump Strainer



Figure 11 - Oil Filter (Pancake Style Filter)

Troubleshooting

◆ Most Likely • Less Likely ♣ Least Likely

| Symptom | Cause | Remedy |
|--|--|--|
| 1. Heater shuts off | ◆ Manual reset | ◆ Requiring manual restart by reset button on |
| 2. Loss of prime overnight | ◆ Vacuum air leak in fuel line | ◆ Check all fuel connections and tighten fittings |
| Won't hold vacuum | ♣ Plugged pump screen | ♣ Check pump screen may need cleaning; to access, remove pump cover |
| Is tank empty? | • Plugged filter or tank oil empty | • Clean filter; using vent port, reprime pump (figures 6 & 7) |
| 3. Fails to start | ◆ Vacuum leak | ◆ Open bleeder port if air present; check and tighten fittings |
| | ◆ Inadequate fuel supply | ◆ Clean filter; check all fuel connections and tighten fittings |
| | • No pressure | • May need cleaning – to access remove pump cover |
| | • No pre-heat | • Be sure all wiring to pre-heater is tight with no loose connections |
| | • Auto start circuit not functioning | • Bad firerod – replace continuity at terminals |
| | • No arc | • Check circuit control board and replace if necessary (call factory) |
| | | • Check continuity at terminals of firerod limit snap switch; replace if needed |
| | | • Check springs to electrode rod adjustment (under transformer) and make sure they make good contact |
| | | • Open burner door and make sure electrode tips aren't touching flame cone or one another – readjust |
| 4. Hard starting diminished | ◆ Partially plugged filter | ◆ Clean filter; using vent bleeder port on pump, re-prime pump (figure 6 & 7) |
| | ♣ Out of fuel | ♣ Refill storage |
| | ♣ No oil to burner | ♣ Check pump screen; remove pump cover and clean if needed. Using vent bleeder port, re-prime pump (figures 6 & 7) |
| | • Inadequate combustion air from burner | • Remove nozzle and check for foreign objects (figures 9 & 10) |
| | | • Aluminum block pre-heater & nozzle inside the burner tube housing. If any build up occurs clean nozzle, flame-cone and pre-heater block if passageways are blocked |
| | | • Backdraft in combustion chamber may be present – check draft up flue pipe and over fire at vision port |
| | • Air band open too far | • Close air band while viewing flame; open air band slowly until combustion chamber is clear, not orange |
| 5. Heater cycles frequently, without thermostat temperature setting being achieved in area to be heated | ◆ Heater over firing | ◆ Investigate and locate reason for over firing; check and clean end cone turbulaor if needed |
| | ◆ Inadequate combustion air from burner | |
| | ♣ Temperature setting wrong | ♣ Check temperature setting and adjust as necessary |
| | ♣ On high limit fan safety switch | |
| | • High limit safety switch bad | • Replace high limit fan safety switch |
| 6. Heater rumbles and excessive heat blow back from flame vision port | ◆ Pump setting wrong | ♣ Clean ash buildup in combustion chamber and exchangers |
| | ♣ Draft incorrect – if proper draft cannot be achieved, consider any exhaust fans in building if added since initial install | ♣ Set draft; clean out combustion chamber and exchangers of ash; check draft and reset if needed |
| 7. Heater establishes flame but locks out or shuts off; need to reset primary | ◆ Photo eye can't see flame | ◆ Clean photo eye, which may be clouded by back draft smoke |
| | ♣ Due to backdraft, flame end cone may have ash | ♣ Swing open burner door and clean ash buildup from flame end cone (figure 5 & 8) |
| | • Bad or uncontrolled flame due to nozzle erosion | ◆ Replace nozzle |

Troubleshooting Continued

| Symptom | Cause | Remedy |
|---|--|--|
| 8. Proper draft setting cannot be achieved | ◆ Negative draft in building or exhaust fans present | ◆ May need to install power vent/draft inducers in stack (see figure 2 for wiring) |
| | ♣ Excessive ash buildup | ♣ Clean ash and soot from combustion chamber and heat exchangers |
| 9. Poor or reduced heat production | ◆ Flame too small | ◆ Nozzle or preheater block may be plugged with carbon debris |
| | ♣ Entire fuel supply may be plugged | ♣ Clean filter, both oil strainer and check oil pump screen |
| | • Excessive ash buildup exchangers | • Clean ash from combustion chamber and exchangers |
| | • Through vision port, check flame to see if flame is smaller than usual or too large and uncontrolled | |

EH-350 Ten (10) Year Limited Warranty

EconoHeat (manufacturer) warrants to the purchaser of Unit Heaters listed above will be free from defects in materials and workmanship for the durations specified below, which duration begins on the date of delivery to the customer. Customer is responsible for maintaining proof of date of delivery.

If return is deemed necessary for warranty evaluation and determination of repair or replacement, unit heater is to be sent to the factory with freight prepaid. EconoHeat reserves the right to determine appropriate action for repair or replacement.

No parts will be accepted by EconoHeat without RA# (return authorization number) clearly marked on outside of shipping package. Obtaining RA# requires model and serial numbers, description of part being replaced and nature of defect. Call factory to receive RA#.

Warranty Covers:

- Combustion chamber and heat exchanger ten (10) years limited, full repair or replacement (parts only), first three (3) fully covered / last seven (7) 50% coverage
- Oil heater block, one (1) years (parts only)
- Oil heater block controller PCB, three (3) years (parts only)
- All other components, one (1) year (parts only)

EH-350 Ten (10) Year Limited Warranty Cont.

This warranty is void if:

- **Warranty registration card is not returned within sixty (60) days of purchase**
- Any part or component subject to abuse or altered from original manufactures specifications
- Installation not in accordance with instructions
- Has not been properly maintained, operated or has been misused
- Wiring not in accordance with diagram furnished with unit heater
- Unit heater is operated in the presence of chlorinated vapors
- Air through unit heater is not in accordance with rating plate and specifications
- Target plate or clean out door warped/discolored from excessive heat

Warranty is limited to the original purchaser and is non-transferable.

The above warranty is in lieu of all other warranties expressed or implied. EconoHeat does not authorize any person or representative to make or assume any other obligation or liability that is not in accordance with above warranty. **EconoHeat is not responsible for any labor and/or shipping cost, unless prior authorization in writing has been obtained.**

NOTE: Combustion Chamber Warranty is specific to material and workmanship. Workmanship means EconoHeat warranties the welds are good and will hold. Material means they will not corrode through due to sulfur in the ash that accumulates during operation. Warranty does not apply to units that experience overheating stress cracks. These are not incurred because the materials are inadequate for the application nor are they results of a weld breaking lose because of bad penetration, which is easily recognized by the metal left beneath the weld. These cracks occur as a direct result of (1)improper draft, either by inadequate initial installation and setup, which requires (a) establishing a proper draft during installation (b) back draft has occurred due to ash buildup, backing up hot gas passageways in either the exchangers, the stack, or both. (2) Over firing by setting oil supply pressure too high (see manual for proper setting) these are all cases of thermal overload.

*Under normal use only. If misuse or abuse is deemed apparent after inspection, warranty is void.

Warranty Card

Please fill out, tear off and return to manufacturer within sixty (60) days of purchase, or warranty will not be valid. Please print or type.

Date of Purchase: _____

Serial #: _____

Model #: _____

Customer (Company) Name: _____

Address: _____

City: _____ State: _____ Zip Code: _____

Dealer: _____

Address: _____

City: _____ State: _____ Zip Code: _____

Installed By: _____